

COMMON MODE CHOKE COIL

LS6/LH6 SERIES



FEATURES

- Excellent frequency characteristics.
- Use of insulating material having superior flame resistance
- Available either vertical mounting type, or horizontal mounting type.

APPLICATIONS

- Personal computers and peripherals.
- Digital equipments.
- Switching power sources, and switching power supply.
- Various types of electronic equipment.

SPECIFICATIONS

Model	Rated Voltage (AC,DC)	Rated Current (A)	Inductance (mH)	Operating Temperature
LS/LH606868	250V	1.8	86.8	-25°C to + 120°C Including temperature rise
LS/LH607607	250V	2.2	60.7	
LS/LH608594	250V	2.5	59.4	
LS/LH609546	250V	3.0	54.6	
LS/LH609180	250V	4.0	18.0	
LS/LH610372	250V	3.5	37.2	
LS/LH611281	250V	4.8	28.1	
LS/LH612202	250V	5.5	20.2	
LS/LH613104	250V	6.0	11.0	
LS/LH614046	250V	12	4.6	
LS/LH614075	250V	7.2	7.5	
LS/LH615014	250V	13	1.4	
LS/LH615025	250V	10	2.5	
LS/LH615062	250V	8.5	6.2	
LS/LH616022	250V	12	2.2	
LS/LH616054	250V	10	5.4	
LS/LH617044	250V	12	4.4	
LS/LH619026	250V	14.8	2.6	

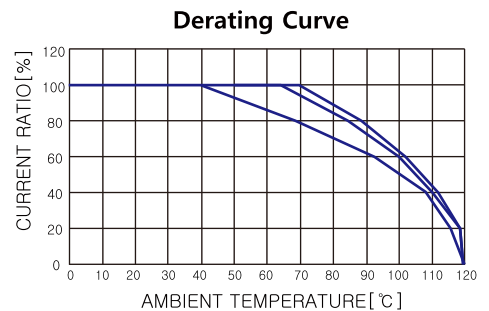

Note : Test Voltage : 2000V AC one minute, line to line.
Insulation Resistance : 300 Mohm min. at 500V DC.

Model Number Construction

LS6

Series Description
LS6:Vertical Type
LH6:Horizontal Type

13

Dia. of Copper Wire
See shapes and
Dimensions next page

104

Rated Inductance
See Specifications
Inductance

Shapes and Dimensions

* LS6-Series

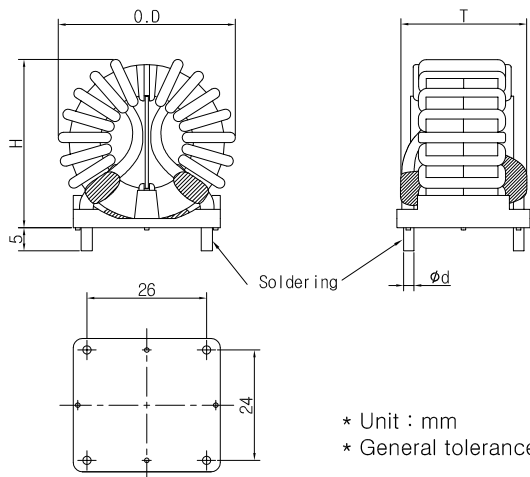

* Unit : mm
* General tolerance : ±1.5

* LH6-Series

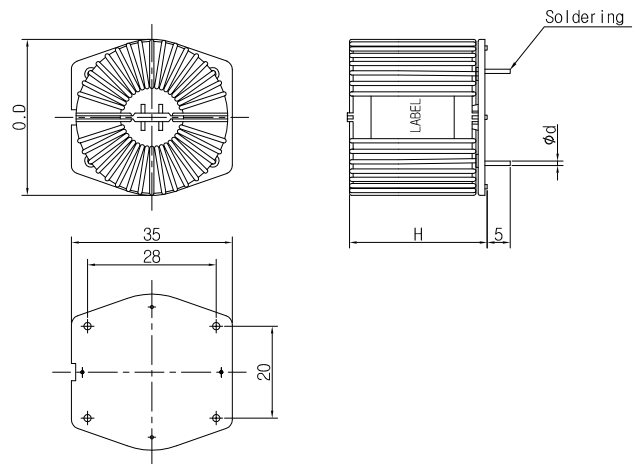

Model	O.D(max)	H(max)	T(max)	ϕ d
LS606868	38.5	38	30	0.6
LS607607	38.5	38	30	0.7
LS608594	38.5	38	30	0.8
LS609546	38.5	38	30	0.9
LS609180	38.5	38	30	0.9
LS610372	38.5	38	30	1.0
LS611281	38.5	40	30	1.1
LS612202	38.5	40	30	1.2
LS613104	38.5	40	30	1.3
LS614046	38.5	38	30	1.4
LS614075	38.5	40	30	1.4
LS615014	38.5	38	30	1.5
LS615025	38.5	38	30	1.5
LS615062	41	41	32	1.5
LS616022	38.5	38	30	1.6
LS616054	41	41	32	1.6
LS617044	41	41	32	1.7
LS619026	41	41	32	1.9

Model	O.D(max)	H(max)	ϕ d
LH606868	38.5	30	0.6
LH607607	38.5	30	0.7
LH608594	38.5	30	0.8
LH609546	38.5	30	0.9
LH609180	38.5	30	0.9
LH610372	38.5	30	1.0
LH611281	38.5	30	1.1
LH612202	38.5	30	1.2
LH613104	38.5	30	1.3
LH614046	38.5	30	1.4
LH614075	38.5	30	1.4
LH615014	38.5	30	1.5
LH615025	38.5	30	1.5
LH615062	41	32	1.5
LH616022	38.5	30	1.6
LH616054	41	32	1.6
LH617044	41	32	1.7
LH619026	41	32	1.9

Circuit Diagram

